

PLATEN MOUNTED ELECTRODE HOLDERS

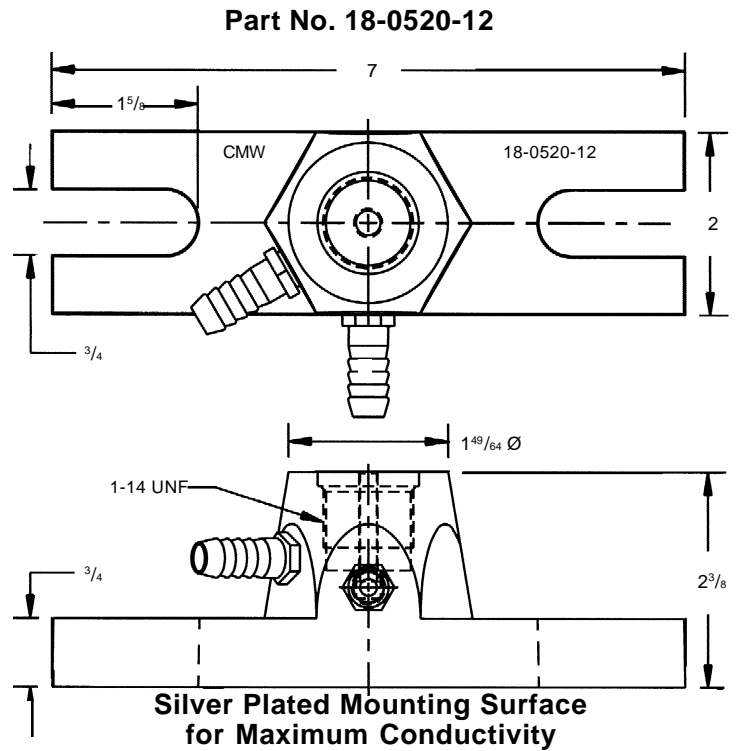

NSRW Co., Inc. (800) 933-6779, FAX: (205) 663-3221 Authorized Distributor CMW Inc.

CMW platen mounted electrode holders provide an economical means of mounting a wide range of electrodes in all the popular sizes to your press type welder platens. They are machined R.W.M.A. class 2 material to provide years of reliable service.

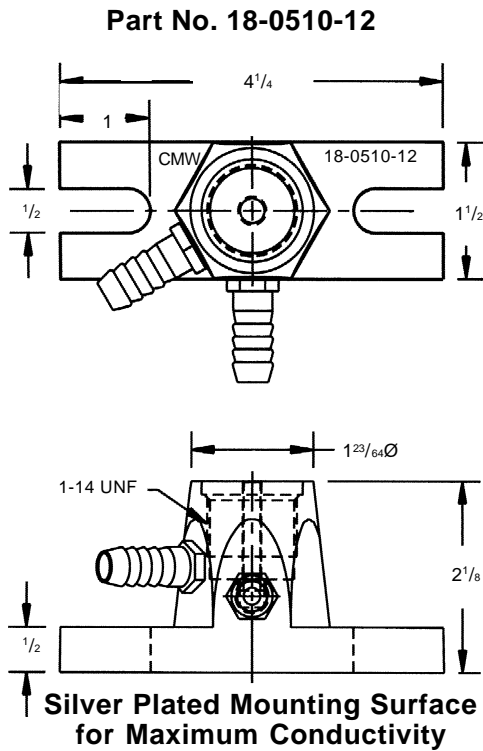

CMW platen mounted electrode holders are machined from CMW® 3 (RWMA class 2) chrome copper castings. They are designed to mount to press type welder platens from size #1 with the small holder to sizes #2 and #3 with the large holder. Both holders are provided with a 1-14 internal thread which will accept the standard male thread to female taper adapters, #4RW, #5RW, #6RW, and #7RW, as shown on page 27 of this catalog, and the #2 size "Nu-Twist"™ threaded adapter as shown on page 36 of this catalog. Both holders are provided with inlet and outlet water nipples for standard 3/8" water lines and a stationary water tube. Adapters and sliding water tubes must be ordered separately, by part number as required (see fig. #1).

The CMW platen mounted holder, as indicated in figure #2, has the inlet water nipple at position #1, and the outlet water nipple at position #2, any other combinations may be special ordered by changing the last two digits of the part number. The first of the last two digits indicates the location of the inlet nipple and the second digit indicates the location of the outlet nipple.

Example; part #18-0510-56 would place the inlet water nipple at position #5 and the outlet water nipple at position #6.

When ordering either CMW PM holder also specify the adapter(s) and sliding tube(s) required for your application.

1-14 male thd to female taper adpt. as shown on page 27 of this catalog.	ATTACHMENT	SLIDING TUBE	SLIDING TUBE O.A.L.
18-785	4RW	18-50041-3	1 3/8
18-786	5RW	18-40043-11	1 3/8
18-7863	6RW	18-40043-14	2 1/8
18-787	7RW	18-40043-15	2 3/8
18-812	#2 SIZE "Nu-Twist"™	NONE	-

STATIONARY WATER TUBE
18-40041-5

Additional Sliding Tubes Available	O.A.L.	FOR TAPER
18-50041-2	2 1/2	4RW
18-40043-5	2	5RW
18-40043-9	4	5RW,6RW,7RW

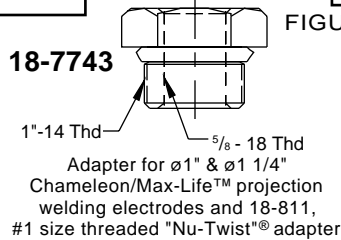

FIGURE #1

