

# 600 SERIES UNIVERSAL WATER COOLED ELECTRODE HOLDERS

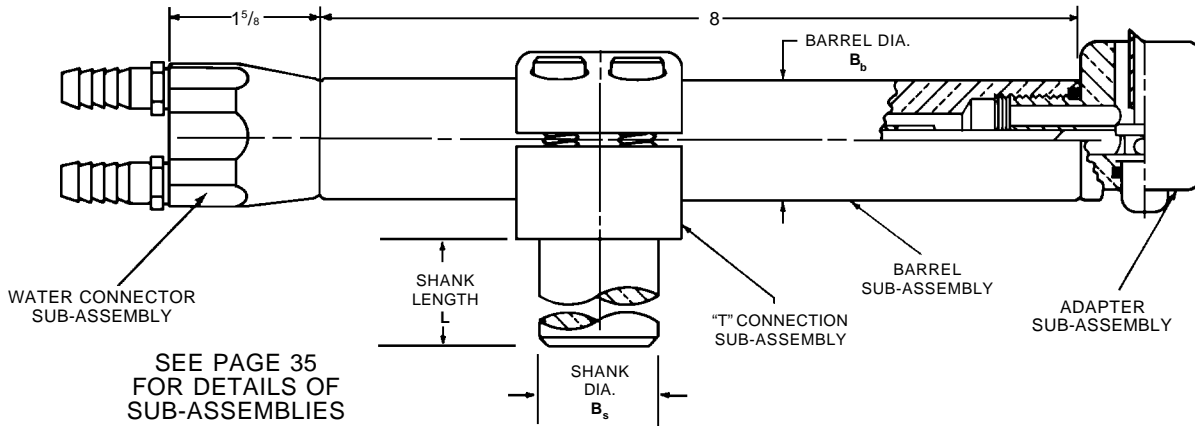

NSRW Co., Inc. (800) 933-6779, FAX: (205) 663-3221 Authorized Distributor CMW Inc.



Part No.	Head Angle	Bbl. Dia. B <sub>b</sub>	Shank Dia. B <sub>s</sub>	Shank Length L	Head Assy.	Bbl. Assy.	"T" Conn. Assy.
----------	------------	--------------------------	---------------------------	----------------	------------	------------	-----------------

### 4RW 1MT

18-601	90°				18-764		
18-602	30°	1	7/8	3	18-765		18-725
18-603	90°				18-764	18-701	18-725
18-604	30°	1	1	3	18-765		
18-605	90°				18-764		
18-606	30°	1 1/4	1 1/4	3 1/2	18-765		18-727
18-607	90°				18-764	18-702	18-730
18-608	30°	1 1/4	1 1/2	4	18-765		

### 5RW 2MT

18-611	90°				18-766		
18-612	30°	1	7/8	3	18-767		18-725
18-613	90°				18-766	18-701	18-726
18-614	30°	1	1	3	18-767		
18-615	90°				18-766		
18-616	30°	1 1/4	1 1/4	3 1/2	18-767		18-727
18-617	90°				18-766	18-702	18-730
18-618	30°	1 1/4	1 1/2	4	18-767		
18-621	Str.	1	7/8			18-701	18-725
18-622	Str.	1	1	3			18-726
18-623	Str.	1 1/4	1 1/4	3 1/2	18-768	18-702	18-727
18-624	Str.	1 1/4	1 1/2	4			18-730
18-651	90°				18-780		
18-652	30°	1 1/4	1 1/4	3 1/2	18-781		18-727
18-657	90°				18-780	18-704	18-730
18-658	30°	1 1/4	1 1/2	4	18-781		

Part No.	Head Angle	Bbl. Dia. B <sub>b</sub>	Shank Dia. B <sub>s</sub>	Shank Length L	Head Assy.	Bbl. Assy.	"T" Conn. Assy.
----------	------------	--------------------------	---------------------------	----------------	------------	------------	-----------------

### 5RW 2MT

18-655	90°				18-780		
18-656	30°	1 1/2	1 1/4	4	18-781	18-705	18-728
18-653	90°				18-780		
18-654	30°	1 1/2	1 1/2	4	18-781	18-705	18-729
18-671	Str.	1 1/4	1 1/4	3 1/2		18-704	18-727
18-672	Str.	1 1/2	1 1/2	4		18-705	18-729
18-673	Str.	1 1/2	1 1/4		18-784	18-705	18-728
18-674	Str.	1 1/4	1 1/2	4		18-704	18-730

### 5RW 2MT with Threaded Adapter

18-6515	90°				18-7805		
18-6525	30°	1 1/4	1 1/4	3 1/2	18-7815	18-704	18-727
18-6535	90°				18-7805		
18-6545	30°	1 1/2	1 1/2	4	18-7815	18-705	18-729

### 6RW with Threaded Adapter

18-6516	90°				18-7806		
18-6526	30°	1 1/4	1 1/4	3 1/2	18-7816	18-704	18-727
18-6536	90°				18-7806		
18-6546	30°	1 1/2	1 1/2	4	18-7816	18-705	18-729

### 7RW 3MT

18-661	90°				18-782		
18-662	30°	1 1/4	1 1/4	3 1/2	18-783	18-704	18-727
18-665	90°				18-782		
18-666	30°	1 1/2	1 1/4	4	18-783	18-705	18-728
18-663	90°				18-782		
18-664	30°	1 1/2	1 1/2	4	18-783	18-705	18-729

BARREL SUB. ASSY.	BARREL PART NO.	WATER CONNECT. SUB ASSY.
18-701	18-37210-8	18-74000-8
18-702	18-37310-8	
18-704	18-37510-8	
18-705	18-37610-8	