

100 SERIES (NON-EJECTOR) WATER COOLED ELECTRODE HOLDERS

NSRW Co., Inc. (800) 933-6779, FAX: (205) 663-3221 Authorized Distributor CMW Inc.

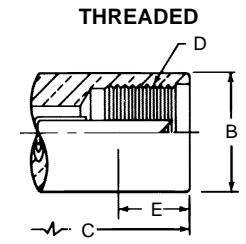

ADAPTERS FOR USE WITH THREADED

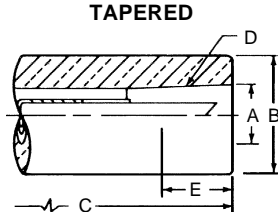
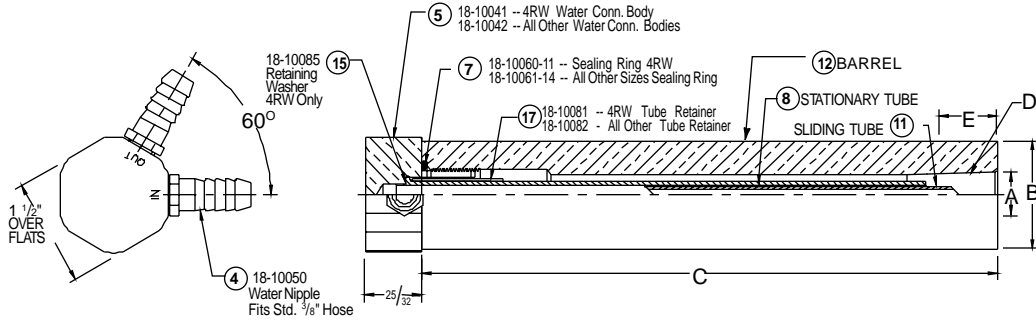
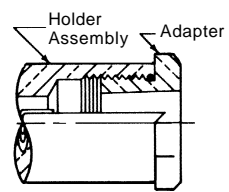

HOLDER ASSEMBLY PART NUMBER	HOLDER SIZE					Water Connection Head Sub-Assembly Include Parts: 4 5 7 8 15 17	⑧ Stationary Tube	⑪ Sliding Tube	⑫ Barrel
	A Major Taper Dia.	B Barrel Dia.	C Barrel Length	D Taper Or Thread	E Engagement with Std. Electrode				
18-101 18-102 18-103 18-104	.463	3/4 7/8 1 1 1/4	3	4RW 1MT	1/2	18-10091-3	18-10044-3	18-10046-3	18-11110-3 18-11210-3 18-11310-3 18-11410-3
18-106 18-107 18-108	.625	1 1 1/4 1 1/2	3	5RW 2MT	3/4	18-10092-3	18-10045-3	18-10047-3	18-11610-3 18-11710-3 18-11810-3
18-111 18-112 18-113 18-114	.463	3/4 7/8 1 1 1/4	8	4RW 1MT	1/2	18-10091-8	18-10044-8	18-10046-8	18-11110-8 18-11210-8 18-11310-8 18-11410-8
18-116 18-117 18-118	.625	1 1 1/4 1 1/2	8	5RW 2MT	3/4	18-10092-8	18-10045-8	18-10047-8	18-11610-8 18-11710-8 18-11810-8
18-119 18-120	.875	1 1/4 1 1/2	8	7RW 3MT	1 1/8	18-10092-8	18-10045-8	18-10047-8	18-11910-8 18-12010-8
18-131 18-132 18-133 18-134	.463	3/4 7/8 1 1 1/4	12	4RW 1MT	1/2	18-10091-12	18-10044-12	18-10046-8	18-11110-12 18-11210-12 18-11310-12 18-11410-12
18-136 18-137 18-138	.625	1 1 1/4 1 1/2	12	5RW 2MT	3/4	18-10092-12	18-10045-12	18-10047-8	18-11610-12 18-11710-12 18-11810-12
18-169 18-170 18-171	—	1 1 1/4 1 1/2	8	5/8-18	9/16	18-10092-8	18-10045-8	18-10047-8	18-16910-8 18-17010-8 18-17110-8
18-172 18-173 18-174	—	1 1 1/4 1 1/2	8	7/8-14	9/16	18-10092-8	18-10045-8	18-10047-8	18-17210-8 18-17310-8 18-17410-8
18-175 18-176	—	1 1/4 1 1/2	8	1-14	3/4	18-10092-8	18-10045-8	18-10047-8	18-17510-8 18-17610-8

Holder Assembly No.	Adapter Part No.	Page	Attachment Description	
18-169 18-170 18-171	Use With 18-750 18-751 18-752 18-811	29 27 27 36	4RW 1MT Female	May also be used with universal Adapters having 7/8-14 Male thread SEE PAGE 35
			5RW 2MT Female	
			5/8-18 M. Thd. #1 Size "Nu-Twist" [®]	
18-172 18-173 18-174	Use With 18-770 18-771	27 27	4RW 1MT Female	May also be used with universal Adapters having 1-14 Male thread SEE PAGE 35
			5RW 2MT Female	
18-175 18-176	Use With 18-785 18-786 18-7863 18-787 18-812	27 27 27 27 36	4RW 1MT Female	May also be used with universal Adapters having 1-14 Male thread SEE PAGE 35
			5RW 2MT Female	
			6RW Female	
			7RW 3MT Female #2 Size "Nu-Twist" [®]	

ORDER BY CMW PART NUMBER ONLY

200 SERIES (EJECTOR) WATER COOLED ELECTRODE HOLDERS

NSRW Co., Inc. (800) 933-6779, FAX: (205) 663-3221 Authorized Distributor CMW Inc. 7RW 3MT MORSE TAPER ASSY. Adapter 18-20033

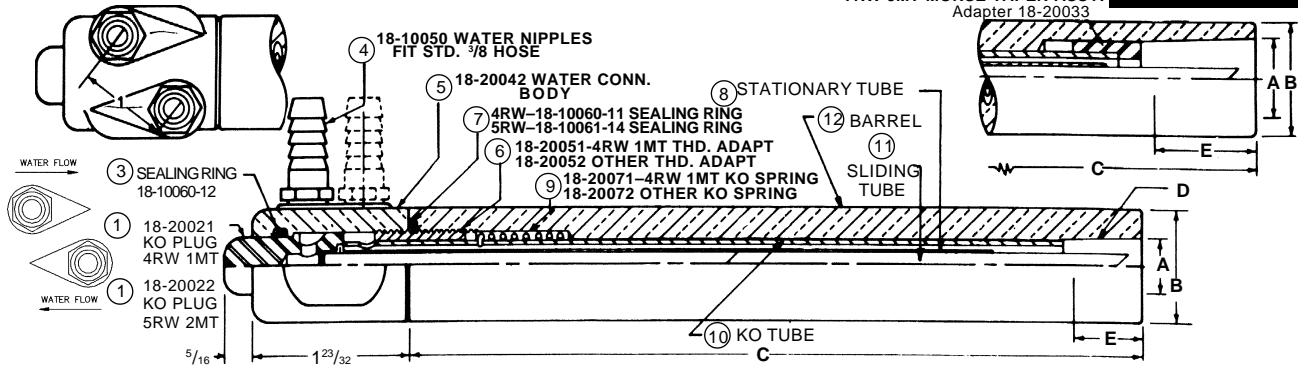

HOLDER ASSEMBLY PART NUMBER	HOLDER SIZE					Water Conn. Hd. Sub-Assy. Include Parts: 1 3 4 5 6 7	KO Tube Sub-Assembly Include Parts: 8 9 10 11	⑧ Stationary Tube	⑩ KO Tube	⑪ Sliding Tube	⑫ Barrel
	A Major Taper Dia.	B Barrel Dia.	C Barrel Length	D Taper Or Thread	E Engrt. with Std. Elect.						
TAPERED											
18-201		3/4		4RW	1/2	18-20091	18-20095-3	18-10044-3	18-20031-3	18-10046-3	18-11110-3
18-202	.463	7/8	3	4RW	1MT						18-11210-3
18-203		1		1MT							18-11310-3
18-204		1 1/4									18-11410-3
18-206		1									18-11610-3
18-207	.625	1 1/4	3	5RW	3/4	18-20092	18-20096-3	18-10045-3	18-20032-3	18-10047-3	18-11710-3
18-208		1 1/2		2MT							18-11810-3
18-211		3/4		4RW	1/2	18-20091	18-20095-8	18-10044-8	18-20031-8	18-10046-8	18-11110-8
18-212	.463	7/8	8	4RW	1MT						18-11210-8
18-213		1		1MT							18-11310-8
18-214		1 1/4									18-11410-8
18-216		1									18-11610-8
18-217	.625	1 1/4	8	5RW	3/4	18-20092	18-20096-8	18-10045-8	18-20032-8	18-10047-8	18-11710-8
18-218		1 1/2		2MT							18-11810-8
18-219		1 1/4		7RW							18-11910-8
18-220	.875	1 1/2	8	3MT	1 1/8	18-20092	18-20096-58	18-10045-8	18-20032-58 & 18-20033	18-10047-8	18-12010-8
18-231		3/4		4RW	1/2	18-20091	18-20095-12	18-10044-12	18-20031-12	18-10046-8	18-11110-12
18-232	.463	7/8	12	4RW	1MT						18-11210-12
18-233		1		1MT							18-11310-12
18-234		1 1/4									18-11410-12
18-236		1									18-11610-12
18-237	.625	1 1/4	12	5RW	3/4	18-20092	18-20096-12	18-10045-12	18-20032-12	18-10047-8	18-11710-12
18-238		1 1/2		2MT							18-11810-12
18-236-18		1									18-11610-18
18-237-18	.625	1 1/4	18	5RW	3/4	18-20092	18-20096-18	18-10045-12	18-20032-18	18-10047-29	18-11710-18
18-238-18		1 1/2		2MT							18-11810-18
18-272		1									18-17210-8
18-273	—	1 1/4	8	7/8-14	9/16	18-20092	18-20096-8	18-10045-8	18-20032-8	18-10047-8	18-17310-8
18-274		1 1/2									18-17410-8
18-275		1 1/4									18-17510-8
18-276	—	1 1/2	8	1-14	3/4	18-20092	18-20096-8	18-10045-8	18-20032-8	18-10047-8	18-17610-8

EJECTOR TYPE ADAPTERS 7/8-14 THREAD

ADAPTER PART NO.	MALE THREAD Size L	FEMALE TAPER		Length Under Head M	Hex Over Flats H	Overall Length C	Sealing Ring Part No.	KO Plug Part No.
		Size D	Major Diameter A					
18-7702	7/8-14	4RW 1MT	.463	5/8	1	13/16	18-76460	18-78501
18-7712	7/8-14	5RW 2MT	.625	1/2	1	1-1/16	18-76460	18-7712-3
Use With Threaded Ejector Holders to make Replaceable Taper Holders						Part No. 18-272 18-273 18-274	Description Threaded Holder 7/8-14 Fem. Thd. 1 Dia. 7/8-14 Fem. Thd. 1 1/4 Dia. 7/8-14 Fem. Thd. 1 1/2 Dia.	
EJECTOR TYPE ADAPTERS 1-14 THREAD								
18-7852	1-14	4RW 1MT	.463	9/16	1-1/4	13/16	18-10060-17	18-78501
18-7862	1-14	5RW 2MT	.625	7/16	1-1/4	1-1/16	18-10060-17	18-7712-3
18-7864	1-14	6RW	.750	3/4	1-1/4	1-3/4	18-10060-17	18-78650
18-7872	1-14	7RW 3MT	.875	3/4	1-1/4	2-1/8	18-10060-17	18-78701
Use With Threaded Ejector Holders to make Replaceable Taper Holders						Part No. 18-275 18-276	Description Threaded Holder 1-14 Fem. Thd. 1 1/4 Dia. 1-14 Fem. Thd. 1 1/2 Dia.	

300 SERIES PREMIUM (EJECTOR) WATER COOLED ELECTRODE HOLDERS

NSRW Co., Inc. (800) 933-6779, FAX: (205) 663-3221 Authorized Distributor CMW Inc.



HOLDER BARRELS ARE CENTERLESS GROUND CMW®3 MATERIAL

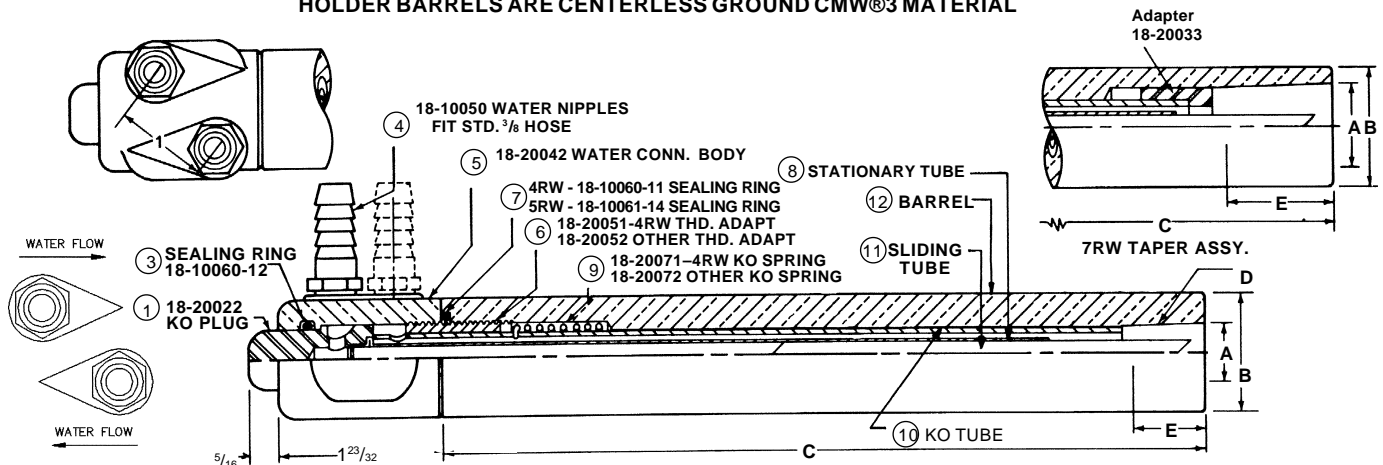

TAPERED SLIDING TUBE	HOLDER ASSEMBLY PART NUMBER	HOLDER SIZE					Water Conn. Hd. Sub-Assy. Include Pts. 1 3 4 5 6 7	KO Tube Sub-Assembly Include Parts: 8 9 10 11	⑧ Stationary Tube	⑩ KO Tube	⑪ Sliding Tube	⑫ Barrel
		A Major Taper Dia.	B Barrel Dia.	C Barrel Length	D Taper or Thread	E Engmt w/Std. Elect.						
	18-317		1 1/4		5RW							1831710-8
	18-318	.625	1 1/2	8	2MT	3/4	18-20092	18-20096-8	18-10045-8	18-20032-8	18-10047-8	1831910-8
	18-319		1 1/4		7RW							1831910-8
	18-320	.875	1 1/2	8	3MT	1 1/8	18-20092	18-20096-58	18-10045-8	18-20033	18-10047-8	1832010-8
	18-337		1 1/4		5RW							1831710-12
	18-338	.625	1 1/2	12	2MT	3/4	18-20092	18-20096-12	18-10045-12	18-20032-12	18-10047-8	1831810-12
	18-339		1 1/4		7RW							1831910-12
	18-340	.875	1 1/2	12	3MT	1 1/8	18-20092	18-20096-62	18-10045-12	& 18-20033	18-10047-8	1832010-12
	18-372		1									18-37210-8
	18-373	—	1/4	8	7/8-14	9/16	18-20092	18-20096-8	18-10045-8	18-20032-8	18-10047-8	18-37310-8
18-375	—	1 1/4									18-37510-8	
18-376	—	1 1/2	8	1-14	3/4	18-20092	18-20096-8	18-10045-8	18-20032-8	18-10047-8	18-37610-8	

Note: These threaded holder barrels same as on 600 Series holders page 34.

CMW PREMIUM HOLDER FEATURES

The CMW Premium Electrode Holder Barrels are made from high strength CMW® 3 material, centerless ground to within .002" tolerance on diameter and Nickel Plated to resist wear and assure uniform contact resistance of a low magnitude. These factors, in addition to the sturdy construction of the ejector mechanisms, plus the ample, well constructed water cooling passage, make these holders ideally suited for use with low frequency, direct current welders, and conventional alternating current machines using high weld currents.

To make replaceable Taper Holders use Adapters from tables at bottom of page 30

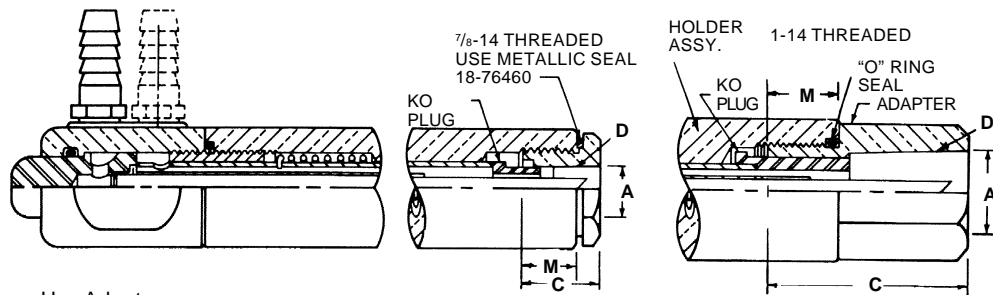

Use Adapters
 18-7702 4RW 1MT }
 18-7712 5RW 2MT }

with 7/8-14 thd'd. Holders

{ 18-372 1 Dia.
 18-373 1 1/4 Dia.

Use Adapters
 18-7852 4RW 1MT }
 18-7862 5RW 2MT }
 18-7864 6RW }
 18-7872 7RW 3MT }

with 1-14 thd'd. Holders

{ 18-375 1 1/4 Dia.
 18-376 1 1/2 Dia.

500 SERIES PREMIUM (EJECTOR) WATER COOLED OFFSET HOLDERS

NSRW Co., Inc. (800) 933-6779, FAX: (205) 663-3221 Authorized Distributor CMW Inc.

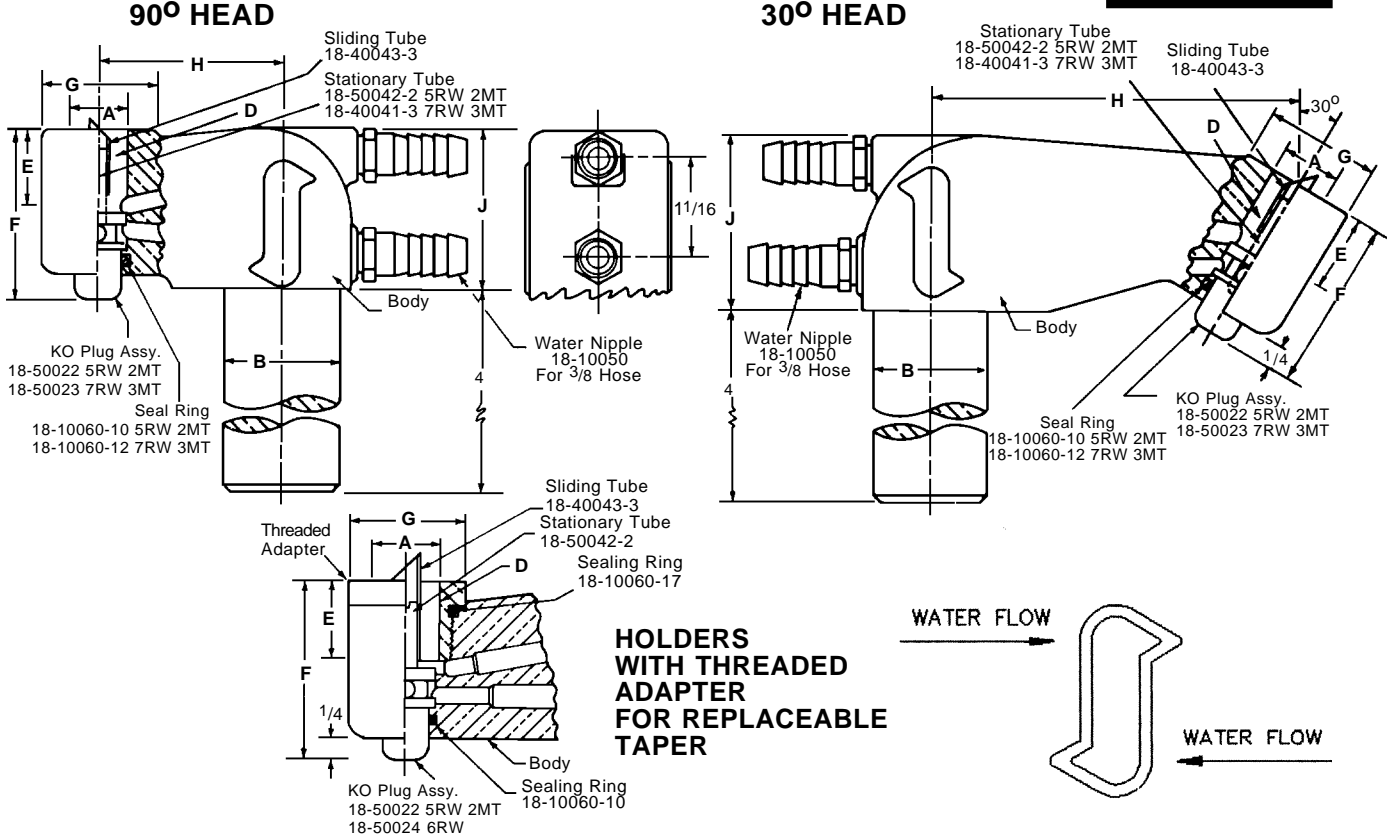

HOLDER ASSEMBLY NUMBER	Angle of Head	Major Taper Dia. A	Shank Dia. B	Taper D	Std. Taper Engagement E	Head Height F	Head Dia. G	C.L. Shank Offset H	Head Thickness J	Threaded Adapter Part No.
------------------------	---------------	--------------------	--------------	---------	-------------------------	---------------	-------------	---------------------	------------------	---------------------------

HOLDERS

18-502 18-503 18-504	90°	.625	1 1 1/4 1 1/2	5RW 2MT	3/4	1 13/16	1 1/4	2	1 23/32	_____
18-505 18-506	90°	.875	1 1/4 1 1/2	7RW 3MT	1 1/8	2 7/32	1 1/2	2	_____	_____
18-522 18-523 18-524	90°	.625	1 1 1/4 1 1/2	5RW 2MT	3/4	1 13/16	1 1/4	4	_____	_____
18-525 18-526	90°	.875	1 1/4 1 1/2	7RW 3MT	1 1/8	2 7/32	1 1/2	4	_____	_____
18-562 18-563 18-564	30°	.625	1 1 1/4 1 1/2	5RW 2MT	3/4	1 13/16	1 5/16	4	1 7/8	_____
18-565 18-566	30°	.875	1 1/4 1 1/2	7RW 3MT	1 1/8	2 7/32	1 9/16	4	_____	_____

HOLDERS WITH THREADED ADAPTER

18-5035 18-5036	90°	.625 .750	1 1/4	5RW 2MT 6RW	3/4 7/8	1 13/16 1 15/16	1 1/4	2	_____	18-7875 18-7876
18-5045 18-5046	90°	.625 .750	1 1/2	5RW 2MT 6RW	3/4 7/8	1 13/16 1 15/16	1 1/4	2	1 23/32	18-7875 18-7876
18-5235 18-5236	90°	.625 .750	1 1/4	5RW 2MT 6RW	3/4 7/8	1 13/16 1 15/16	1 1/4	4	_____	18-7875 18-7876
18-5245 18-5246	90°	.625 .750	1 1/2	5RW 2MT 6RW	3/4 7/8	1 13/16 1 15/16	1 1/4	4	_____	18-7875 18-7876
18-5635 18-5636	30°	.625 .750	1 1/4	5RW 2MT 6RW	3/4 7/8	1 13/16 1 15/16	1 1/4	4	1 7/8	18-7875 18-7876
18-5645 18-5646	30°	.625 .750	1 1/2	5RW 2MT 6RW	3/4 7/8	1 13/16 1 15/16	1 1/4	4	_____	18-7875 18-7876

ORDER BY CMW PART NUMBER ONLY